

## VERSION “H”

The **H** units are “slave units” with a **COMPACT RAIL** U-rail inside. The U-rail and slider allow the units to function and absorb parallelism errors in the mounting structure. The **H** units consist of the aluminum profile, a U-rail and slider, and the trolley. There are no pulleys and there is no belt. These units must always be mounted close together with another **UNILINE** actuator (not another **H** unit).

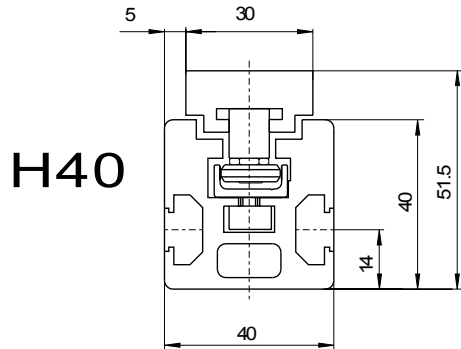

**H40**

Tipo	C <sub>0rad</sub> [N]	C <sub>0ax</sub> [N]	M <sub>x</sub> [Nm]	M <sub>y</sub> [Nm]	M <sub>z</sub> [Nm]
H40	820	0	0	0	13.1
H40L	1640	0	0	0	da 61 a 192
H40D	1640	0	0	0	da 192 a 1558

*Note: the only loads these units can be subjected to are radial load and Mz moment.*

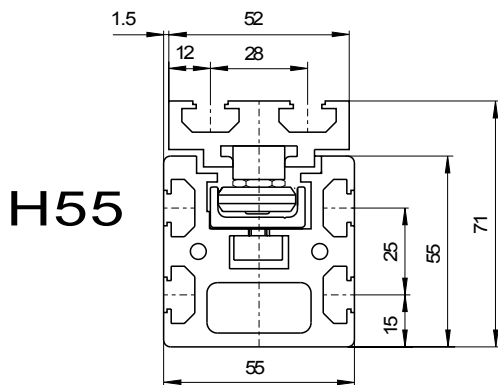

**H55**

Tipo	C <sub>0rad</sub> [N]	C <sub>0ax</sub> [N]	M <sub>x</sub> [Nm]	M <sub>y</sub> [Nm]	M <sub>z</sub> [Nm]
H55	2175	0	0	0	54.4
H55L	4350	0	0	0	da 239 a 652
H55D	4350	0	0	0	da 652 a 6677

*Note: the only loads these units can be subjected to are radial load and Mz moment.*

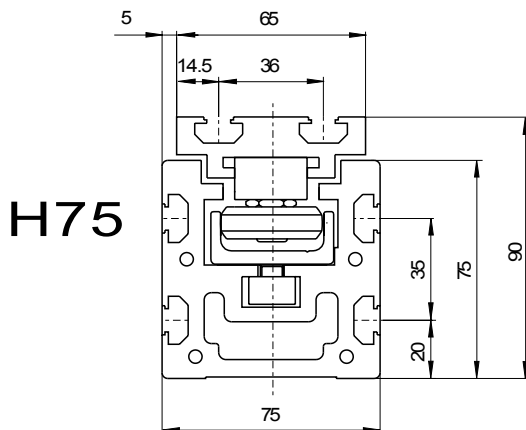

**H75**

Tipo	C <sub>0rad</sub> [N]	C <sub>0ax</sub> [N]	M <sub>x</sub> [Nm]	M <sub>y</sub> [Nm]	M <sub>z</sub> [Nm]
H75	5500	0	0	0	209
H75L	11000	0	0	0	da 852 a 2282
H75D	11000	0	0	0	da 2288 a 18788

*Note: the only loads these units can be subjected to are radial load and Mz moment.*

### Order codes:

**H** **40** - **500**  
 family section stroke  
 (40, 55, 75) (in mm)

**H** **55** - **800** - **400** **L**  
 family section stroke trolley length long trolley  
 (40, 55, 75) (in mm) (in mm) version

**H** **75** - **1000** - **704** **D**  
 family section stroke distance between double trolley  
 (40, 55, 75) (in mm) trolley centers (in mm) version